

THE REPUBLIC OF TURKEY
MINISTRY OF NATIONAL EDUCATION
The General Directorate of Technical and
Vocational Education

13. INTERNATIONAL
MEB ROBOT CONTEST
SUMO-MINI SUMO ROBOT CATEGORIES
THE RULES

2019 - SAMSUN

The Rules of Sumo and Mini Sumo Robot Category

Chapter1 General Rules

(Objective)

Article 1: This document defines the rules and regulations of Sumo Robot Tournament.

Chapter 2 Definition of a match

(Definition)

Article 2: For each robot , a single operator and an assistant can be registered. However, only one competitor will operate the robot. Both contestants have to know the competition rules and obey these rules. Robots must be autonomous robots. The winner will be determined by the judges after the match.

Chapter 3.Specifications of Dohyo

(The Match Ring Area)

Article 3: Definition of Dohyo

1. Dohyo consist of the match ring and the outer layer area of the ring. The rest of the space will be deemed as area which is outside of Dohyo and objections for this area won't be accepted.
2. The specification of Dohyo
 - Dohyo of Sumo Robot is a MDF circle board that is covered by a black SPCC (JIS:Cold-reduced carbon steel) board on top of the 5 cm height, 154 diameter
 - Dohyo of Mini Sumo Robot is a circular MDF board which has 5cm height and 77 cm diameter
3. The dividing line
 - It is the 5cm white area outside of Dohyo of Sumo Robot and it is included to dohyo area.
 - It is the 2,5cm white area outside of Dohyo of Mini Sumo Robot and it is included to dohyo area.

Chapter 4

Specifications of Robot

(The specifications of robot)

Article 4: The specification of robot are as follows.

1. Detailed description of Robot
 - Sumo Robot should be 20cm width and 20cm depth (no restriction on the height) and able to be stored **in a cubic box** for inspection purpose.

- Mini Sumo Robot should be 10cm width and 10cm depth (no restriction on the height) and able to be stored **in a cubic box** for inspection purpose.

2. Controlling Robot

Robots will be autonomous type. It is not allowed remote control except "remote start-stop function"

3. The weight of the robot

- The weight of sumo robot will be maximum 3kg and minimum 1kg.
- The weight of mini sumo robot will be maximum 0,5kg.

4. Starting the movement

Sumo and mini sumo type robots; Judge will start both robots at the same time by remote controller and robots should move in 10sec.

5. Terminating the movement

- a. Judge will stop the robots by using remote controller at the end of round.

6. The rules for using blades.

- a. Paper test will be applied to the robots by the judges. Robots that have very sharp blades won't be accepted.
- b. Using the blades should not cause any damages to Dohyo and injury to spectators. Robots which have materials such as craft knives, razor blade etc. won't be accepted.
- c. Judges will decide whether disqualify the robot which damaging to Dohyo or not.

7. The measures of fire prevention

To prevent the over-current in battery, robots should be equipped with fuse or poly-switch or the blocking by the circuit. Otherwise judges will interfere the robots which are broken or cause dangerous situations.

In case of fire or explosion on robots, judge can stop the match and then judges decide whether the match continue or not. If judges decide to terminate the match, scores of current and remain rounds are given to opponent.

(Movements of Robots)

Article 5: The movements of the robot should be designed to detect the movements of the opponent and respond/attack accordingly. If the movement is suspicious, operation check maybe made by indication of the judges. The check is carried out as the condition that a match terminates without program modification.

(Prohibited items in design and manufacturing of the robots)

Article 6: Prohibitions

1. Any components that may affect the operating frequency or operation of opponents (such as flash) are prohibited.
2. Using any components that may scratch or cause any damages on the surface of dohyo are prohibited
3. Liquid, powder or gas which is used as a weapon or attack mechanism against the opponent. are prohibited

4. Inflammable components should not be installed in the robots.
5. It is not allowed that placing batteries caused to damage Dohyo , other robot or itself.
6. The robot must not include any kind of launching device.
7. The robot must not include any parts that stick the robot to dohyo surface and prevents its movement (such as suckers, glue and so on)

Chapter 5 Game Principles

Article 7: Game Principles

1. In principle, the competition time based on three matches in 3 minutes of each. Team who get two effective points within the competition time will be the winner.
2. If only one single effective point has been got by the end of the competition time, the team that has get this point will be the winner of the competition.
3. In case of equality such as 1-1 or 0-0 , the competition will be extended one more round. In extension time, the team who get 1 effective point will be the winner of the competition.
4. Within the match time, if no team has win any round , 1 effective point is given to lighter robot than other according to robot weight and then the winner is determined.
5. Before the match is over, all maintenance is prohibited.(however, under supervising of judge, competitors can interfere only in 30 seconds without leaving match area and getting any technical support from outside. They also cannot change anything on robot in this moment)

Chapter 6 Carry out the Competition

(Safety measurements)

Article 8: Safety measurements

1. For safety, the competitors should wear goggles, gloves and sports shoes during the match. Teams that miss such safety equipments won't be accepted.

(Beginning of the Game)

Article 9: Competitors must have safety equipments such as glasses, shoes etc.

1. Judges will start the match after checking the dohyo and competitors as well. If there are any scratches/dirt in the dohyo, the judges will decide whether the match can continue on the same dohyo or not.
2. The match will begin when placing robots on Dohyo by the instruction of judges.
3. Placement of robots will be determined by judges as side by side or back to back
4. Robots are not allowed to be moved after they have been placed.

(The ending of the game)

Article 10: The ending of the game

1. Game will officially end upon the announcement of judge.
2. Upon the ending of the match, contestants should be required to terminate the robots by using the remote control.
3. Contestants are required to carry their robots from the outside of dohyo.

(Restart of a match)

Article 11: In the following situations, the match will be suspended and resumed.

- 1- In case of both robots are stuck facing each other and further movements are not possible . it will be waited in 10 second, then after **round restarted by judges.**
- 2- In case of that both robots fall out into the outside of Dohyo simultaneously.
- 3- If winner cannot be determined after 3 rounds, the judge places the robots in a specific position symmetrically and restart 4. round which is last round.

Chapter 7 Points

(Effective point)

Article 12: The winner of round is determined based on the following situations.

- 1- If the opponent robot is forced out of dohyo and the robot touches outside of dohyo.
- 2- If the opponent robot falls out of Dohyo by itself and touches outside of Dohyo
- 3- If the robot stays inactive more than 10 seconds (inactive robot loses the round even if the other robot touches out of Dohyo)
- 4- If some parts described in Article 14 are falling down
- 5- If "warning " was given two times to the opponent.

Chapter 8 Warnings and Penalties

(Warning)

Article 13: A contestant who takes any of the following actions will receive a warning. If a contestant receives two warning, one effective point will be granted to his/her opponent.

- 1- Any violation of Article 6.
- 2- The robot is repositioned after it has been placed in Dohyo.
- 3- All actions that may be deemed unfair / tricky by judges.

(Violations)

Article 14: If the following situation happens, the opponent will be granted one effective point.

- 1- If the components (over than 10gr.) were dropped from the robots
- 2- If the robot doesn't move within 10sec. after starting signal.
- 3- If there is an application from contestants to terminate the match.
- 4- If teams which use magnet on robots cannot take their robots from dohyo within 20 sec.at the end of round.

(Loss because of vialotions)

Article 15: A contestant who takes any of the following actions will lose the game because of violation.

- 1- A contestant doesn't come to the appointed dohyo in 5 minutes.
- 2- A contestant sabotages the game. For example, by intentionally breaking,damaging or defacing dohyo.
- 3- A contestant violates Article 4.
- 4- If robot cannot move as described in Article 5 "the requirements of autonomous robots"
- 5- If the robot fires and then then it causes the robot broken.

(Disqualifications)

Article 16: A contestant who take any of the following actions will be disqualified and forced to leave the game and will not be on the ranking list.

- 1- A contestant's robot does not meet the requirements which is stated in Article 6 "specification of the robots" .
- 2- A contestant doesn't respect the fairplay rules. (For example, using offensive language or assaulting opponents or judges).
- 3- A contestant injures the opponent or judges intentionally.

Chapter 9 Injuries and Accidents

(Request for suspension/postpone)

Article 17: Request for suspension/postpone

- 1- When a contestant is injured and the game cannot be continued , a suspension can be requested by the contestant.
- 2- In the event above , the judges will make necessary arrangements for the game to be resumed immediately.
- 3- If the arrangements made do not enable match to be resumed, the opponent will be declared as a winner without match.

Chapter 10 Objections

Article 18: Objections to appeal against the decisions of judge will be given in written by using web address.

Chapter 11 Specifications of robot marking

(placement direction of robot on Dohyo)

Article 19:

- Judges decide how to place the robots on Dohyo. Head to head placement does not allowed. (In extension rounds, judges will decide the placements of robots on Dohyo symmetrically)
- Before the match, Sumo robots should be placed manually at the same time according to rules shown at Figure 2. It is not allowed to change the position of robots once they were placed on Dohyo.
- Robots will be placed back to back on any place in quadrants as shown in Figure 4

(Robot markings)

Article 20: Photos of robots will be taken and the stickers will be pasted on each of them at the first day of competition.

Chapter 12 Others

Article 21: Tournament Committee is authorized for all kinds of modifications about the rules of contest.

Chapter 13 Dohyo Pictures

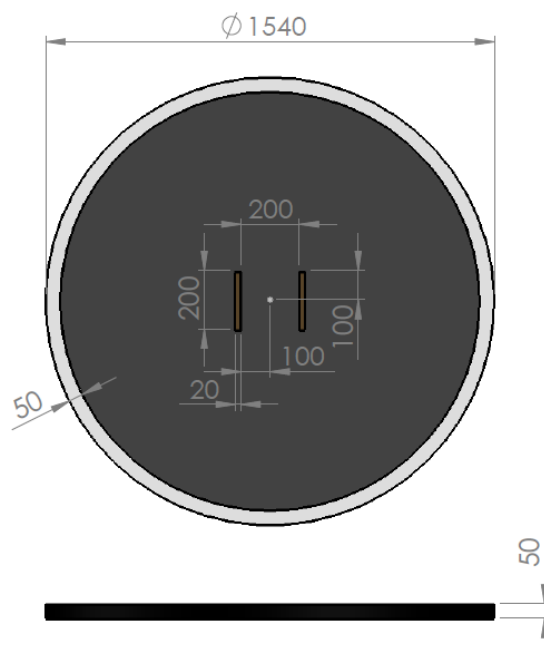

Figure 1 Dimensions of Dohyo for Sumo Robot Competition (mm)

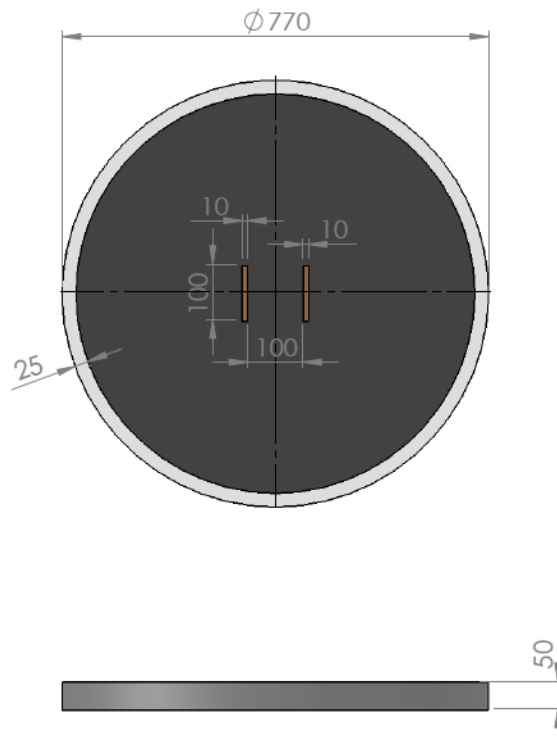

Figure 2 Dimensions of Dohyo for Mini Sumo Robot Competition(mm)

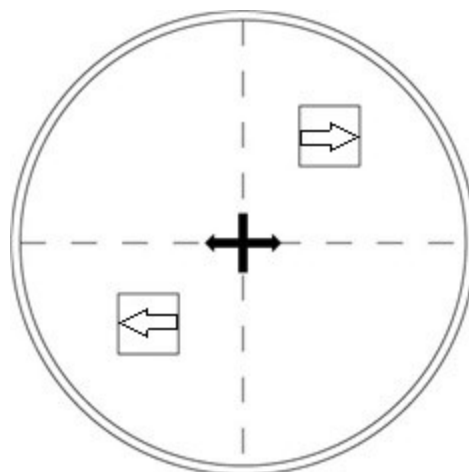
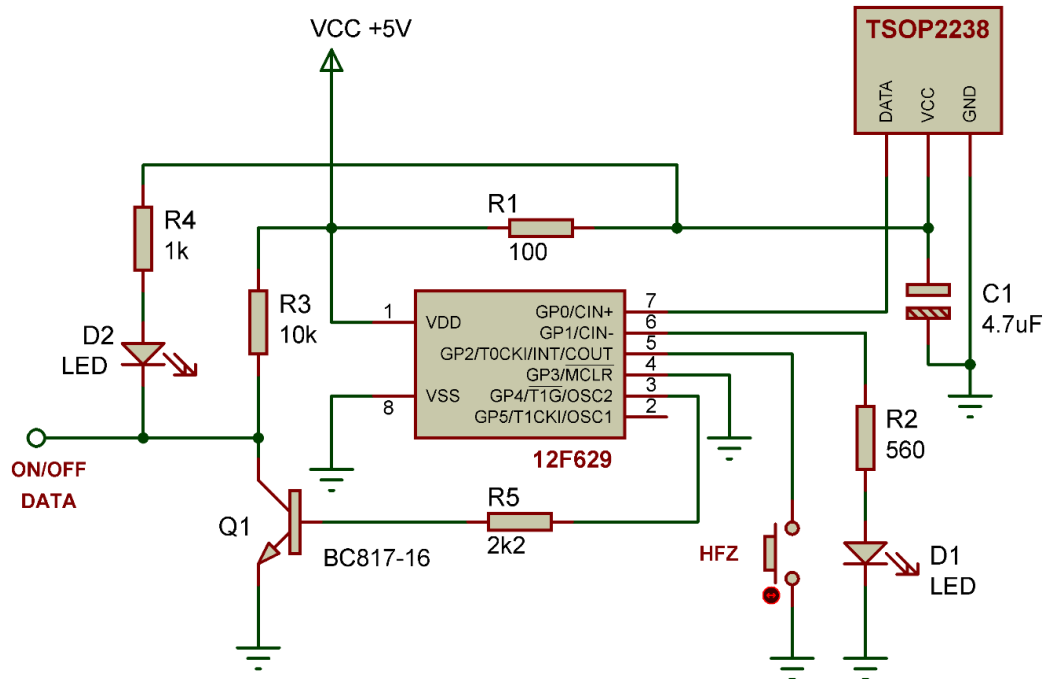

Figure 3 Placement of Mini Sumo Robot on Dohyo

Article 22: Teams will prove Start/stop circuit of Sumo and mini sumo robots **by themselves. No any start/stop module will be given to teams.**

Notice: For mini sumo competition, stopping robot by judge is **not compulsory** . But for Sumo category, **it is compulsory** that robots will be stopped by judge or competitor using remote controller at the end of matches.

START MODULE



Şekil 1 : Start Module circuit

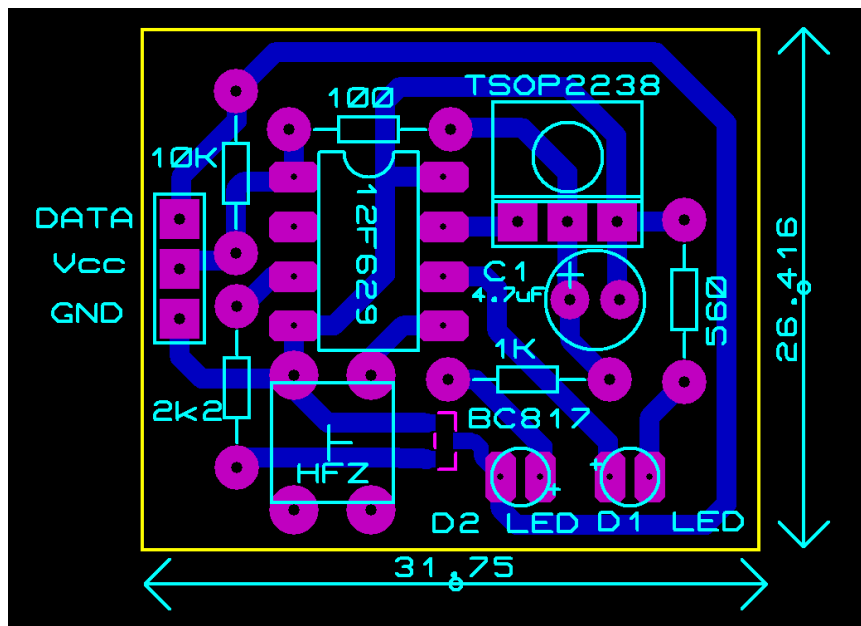

Şekil 2 : Start Module PCB

START MODULE: HOW TO USE

First of all, which button on transmitter will be used for on/off function on receiver side should be determined. You should push memory button on the

receiver and then D1 led turns on permanently. At this time, you should press a button on transmitter two times successively then wait. D1 led will turn off. Now module is ready to use.

To set the output ON, push the button (memorized button on transmitter) one times. D1 led will flash but D2 will turn on permanently. The output voltage drops 0V.

To set the output OFF, push the button (memorized button on transmitter) one times. D1 led will flash but D2 will turn off permanently. The output voltage rises to +5V.

You can use any kind remote controller using "RC5" protocol as a transmitter for this circuit. A special area called "test point" will be reserved for competitors to test their remote modules.

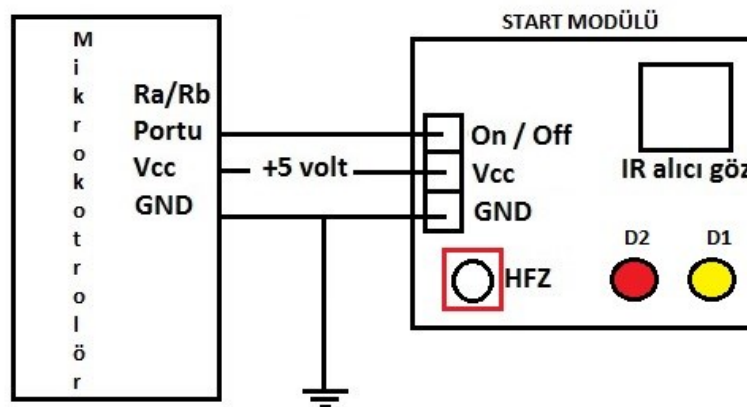
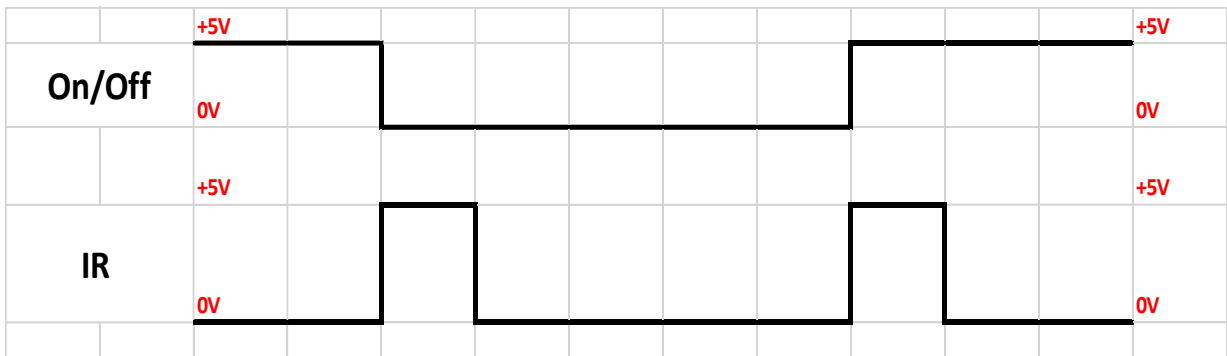

Wiring diagram between MCU and start module